

BOILERSMITH[®]

CENTURION



HF3HX-1950SF-XW-150

Standard inspection openings are now 3 x 4 inch hand holes.
Extra hand holes (not shown) are provided at upper water leg locations.
Flue box door hinges are now as shown inside.

**HIGH PRESSURE
SOLID FUEL BOILERS BY**
■ CANADA'S 🔨 BOILER 🔨 MAKER ■

HF3 SERIES

**VERSATILE
FIREBOX
DESIGN**

HF3 CENTURION SERIES

CENTURION SERIES OVERVIEW

- * HEAVY-DUTY *
- * REFINED DESIGN *

**CONSIDER THE HF3's
- OVERALL EXCELLENCE -**

- Minimal floor area used
- Open furnace bottom adapts to a variety of solid fuel firing equipment
- 2-1/2 inch, 12 GA, SA178A boiler tubes for easier cleaning (attached by rolling, beading and rerolling – no welding)
- Oversized stay rods
- Waterleg/wetback/wetfront construction for superior internal circulation, quicker steaming and higher efficiency
- Outstanding inspection access as well as quick and easy maintenance
- Full wetback firebox construction prevents the short circuiting of flue gases
- Integral front flue box liner protects insulation from wear and damage
- ASME fireside pattern fusible plug
- Generous furnace volume for low heat release combined with abundant primary heat transfer surface.
- AND MORE:
Ask for our detailed specification sheets and dimensional drawing

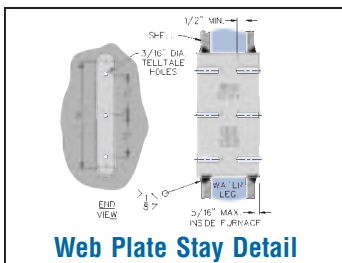

Web Plate Stay Detail

- Super strong web stays are included at critical corner areas
- These ingenious web stays have over 500 percent of the strength of typical round bar stays



- Flushout/inspection openings are 3 x 4 inch hand hole type. Offset studs ease installation
- Extra hand holes are provided in at least 12 strategic locations over and above code requirements

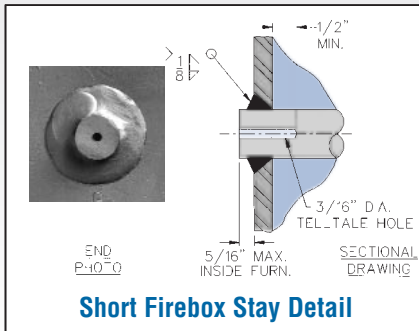

Short Firebox Stay Detail

- Teltale holes enhance inspection accessibility and safe operation

OPTIONS AND ALTERNATIVES

- We specialize in customizing your boiler. The Centurion can be equipped to suit a wide variety of installations and specifications. We will help direct you to the most desirable arrangements and features.

OPTIONAL BASIC STEAM TRIM

- Safety valve(s)
- Water glass set
- Pressure gauge
- Gauge cock
- Pressuretrol line drain
- Trycocks
- Pressuretrol – high limit
- Pressuretrol – operating
- McDonnell Miller 157 low water cutoff and pump control c/w water column blowdown valve
- Warrick 2 probe auxiliary low water cutoff (probe relay POA)
- Feed check and shutoff valves
- Pre-piping of MM157 and removal for shipment as required
- Other items are [POA](#)

OTHER BOILER SERIES OF INTEREST



Locomotive



'Scotch' Waste Heat



Firebox

For hand firing of solid fuel.

Not shown:
Horizontal Return Tubular (HRT)
Low Pressure Firebox gas, oil, or automatic solid fuel firing

BOILERSMITH
CANADA'S BOILER MAKER

P.O. Box 70, 156 Main Street South
Seaforth, Ontario N0K 1W0
Tel: (519) 527-0600 Fax: (519) 527-0150

Bulletin No. CAD 1HF3-10-07M-95

Represented by:

Printed in Canada on Recycled Paper

